

Spectrophotometric determination of bromate in drinking water using a multi-syringe flow injection system

Sara M. Oliveira^{a,c}, Marcela A. Segundo^a,

José L.F.C. Lima^a, Víctor Cerdà^b, António O.S.S. Rangel^c

^aREQUIMTE, Serviço de Química-Física, Faculdade de Farmácia, Universidade do Porto, Rua Aníbal Cunha, 164, 4099-030 Porto, Portugal

^bDepartment of Chemistry, University of the Balearic Islands, Carretera de Valldemossa, Km. 7.5, E-07071 Palma de Mallorca, Spain

^cEscola Superior de Biotecnologia, Universidade Católica Portuguesa, Rua Dr. António Bernardino de Almeida, 4200-072 Porto, Portugal

INTRODUCTION

The potential presence of bromate in drinking water is a public health issue, due to its recognised carcinogenicity. The disinfection process by ozonation might induce the oxidation of bromide ions to bromate, leading to the formation of toxic compounds.

In the present work, a multi-syringe flow injection system for the determination of bromate in drinking water is proposed. The determination is based on the spectrophotometric detection of a coloured cation, resulting from the oxidation of phenothiazine compounds in the presence of bromate, in acidic medium.

MSFIA MANIFOLD AND ANALYTICAL SEQUENCE

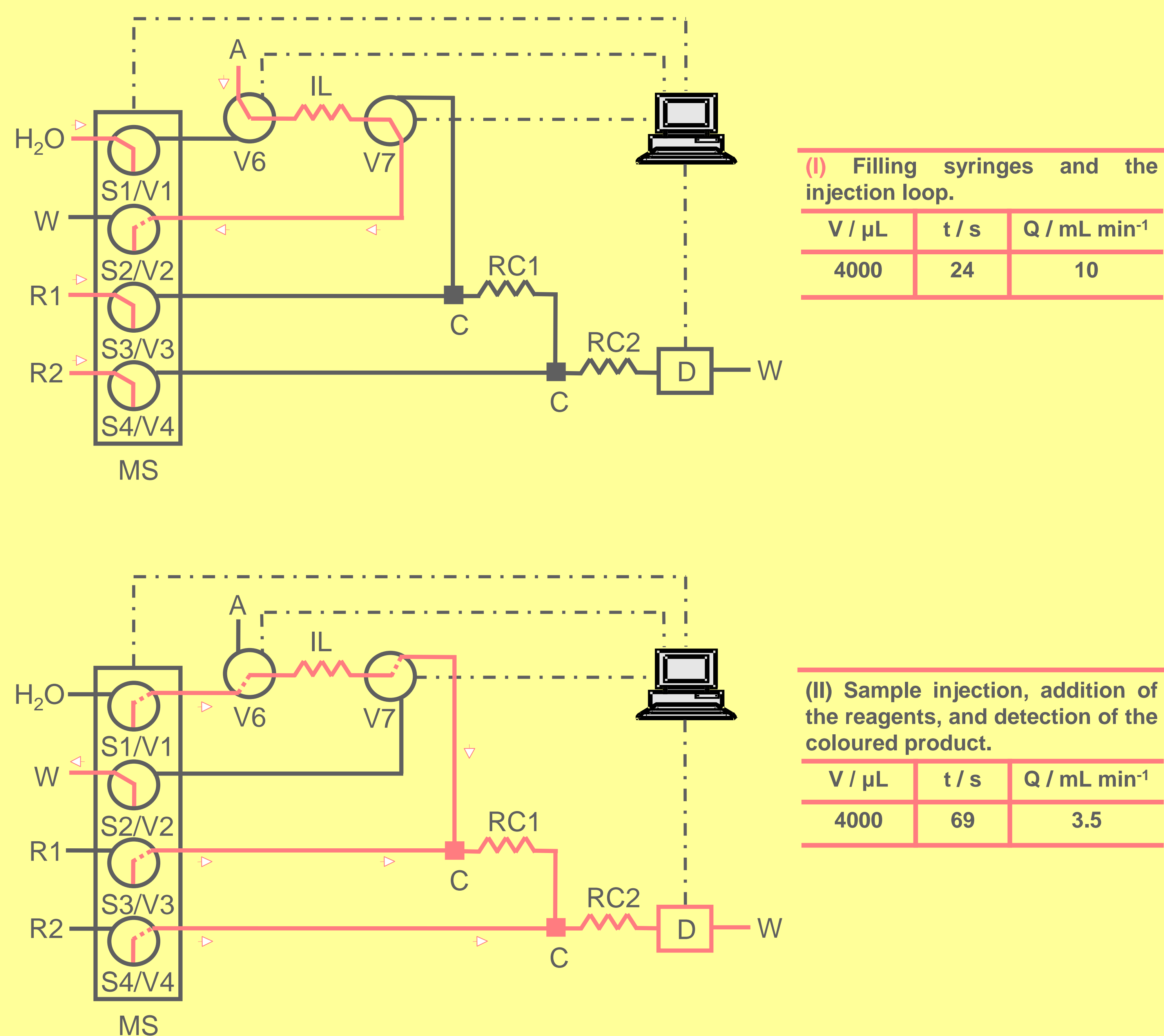

Figure 1. Manifold used for bromate determination in waters. The flow movement in the different channels is indicated for both steps of the analytical cycle. MS: multi-syringe, S_i: syringe (S₁ = S₂ = 10.00 mL, S₃ = 2.50 mL, S₄ = 5.00 mL), V_i: solenoid valve in position "On" (continuous line) or "Off" (discontinuous line), D: spectrophotometer, C: confluence, RC_i: reaction coils (t_{RC1} = 60 cm e t_{RC2} = 160 cm), IL: injection loop (1000 μL), R1: phenothiazine, R2: HCl, A: sample or standard, W: waste; V: volume; t: time; Q: flow rate. The volumes and flow rates indicated correspond to syringe 1.

STUDY OF DIFFERENT PHENOTHIAZINE COMPOUNDS

Table 1. Analytical features of the developed flow system, using three different phenothiazine compounds as colour reagents.

	Chlorpromazine	Trifluoroperazine	Thioridazine
Sensitivity / AU mg^{-1} L	0.535 \pm 0.003	0.346 \pm 0.002	0.351 \pm 0.002
Detection limit / $\mu\text{g L}^{-1}$	8.1	9.8	9.7
HCl per determination / mmol	14	12	12
Reagent per determination / μg	750	500	500
Price per 100 determinations / €	1.50	0.95	0.88

Phenothiazine and 2-(trifluoromethyl)phenothiazine were only soluble in solutions containing 90% of ethanol \rightarrow these compounds were not tested in the developed flow system.

INTERFERING SPECIES EVALUATION

Table 2. Study of potential interfering species, using chlorpromazine, trifluoroperazine and thioridazine as development colour reagents, with a standard solution containing 250 $\mu\text{g L}^{-1}$ of BrO_3^- .

Added species	Concentration tested / mg L^{-1}	Relative deviations (%)		
		Chlorpromazine	Trifluoroperazine	Thioridazine
Cl^-	250	4.4	0.0	1.1
F^-	1.50	1.5	1.2	2.2
SO_4^{2-}	250	0.0	1.2	2.2
Ca^{2+}	100	1.5	-2.6	1.1
Mg^{2+}	50.0	1.5	0.0	2.2
I^-	0.0500	0.8	-3.8	2.2
Br^-	6.00	3.7	2.4	0.0
NO_2^-	0.500	61.6	51.6	61.3
NO_3^-	50.0	1.5	1.1	-3.3
ClO^-	2.00	71.1	50.8	37.9
ClO_2^-	3.00	74.6	64.2	65.8
ClO_3^-	0.500	0.8	1.1	-2.2

Based on these results (Table 1 and Table 2), further studies were carried out using chlorpromazine.

IN-LINE ELIMINATION OF INTERFERENCES

Table 3. Interference elimination procedures.

Interferent	Nitrite	Hypochlorite and chlorite
	Off-line elimination	Sulphamic acid
In-line elimination	HCl 7.0 mol L^{-1} + Sulphamic acid 10.5 g L^{-1}	Chlorpromazine 2.11 mmol L^{-1} + Sulphite 2 g L^{-1}
	Incorporated in syringe 4	Incorporated in syringe 4

APPLICATION TO WATER SAMPLES

Table 4. Application of the flow system with in-line elimination of interferences to water samples.

Added	Bromate concentration / $\mu\text{g L}^{-1}$		
	Water 1	Water 2	
0	< LOD	< LOD	Water 1: Milli-Q water with addition of ClO^- 2.00 mg L^{-1} + ClO_2^- 3.00 mg L^{-1} + NO_2^- 500 $\mu\text{g L}^{-1}$
25	24 \pm 2	< LOQ (21 \pm 2)	
100	89 \pm 3	93 \pm 2	
250	237 \pm 3	240 \pm 2	Water 2: Tap water

FIGURES OF MERIT

Table 5. Figures of merit of the proposed flow system with in-line elimination of interferences.

Linear range / μg^{-1} L	25 - 750
Sensitivity / AU mg^{-1} L	0.471 \pm 0.002
Detection limit / $\mu\text{g L}^{-1}$	7
Quantification limit / $\mu\text{g L}^{-1}$	24
Precision (RSD) / %	<1.6
Determination rate / h^{-1}	35

ACKNOWLEDGEMENTS

S. Oliveira thanks Fundação para a Ciência e a Tecnologia (FCT) and FSE (III Quadro Comunitário) for the grant SFRH/BD/23782/2005. The authors thank CRUP (Conselho de Reitores das Universidades Portuguesas) through Acção Integrada Luso-Espanhola n° E-146/04.