

13th International Conference on Flow Injection Analysis, Las Vegas, April 2005

**Exploiting the multicommutation approach for
calibration using a single standard solution:
application to the determination of mercury by CVAAS**

Fátima Silva, Ildikó V. Tóth, António O. S. S. Rangel



*Escola Superior de Biotecnologia
Universidade Católica Portuguesa
Porto, Portugal*

- Hatch and Ott, Anal. Chem. 40 (1968)
- Standard method for Hg determination (EN 13806, AOAC)

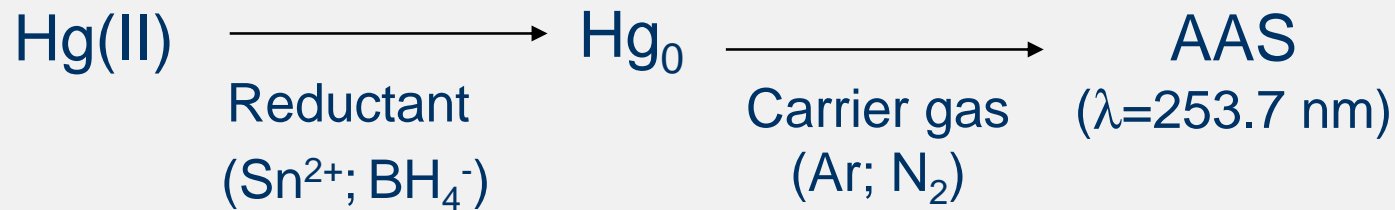

➔ Batch systems

➔ Flow systems

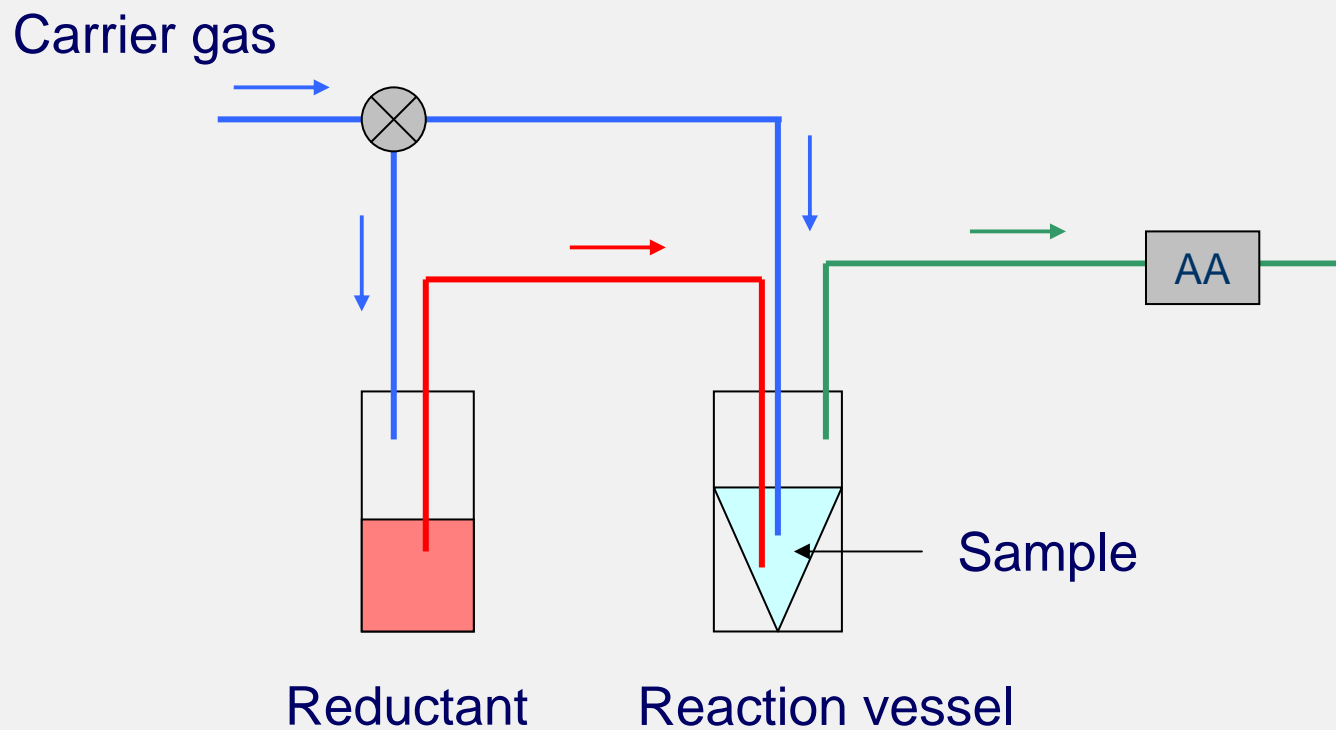

Limitations

- high reagent/sample consumption
- time consumption

⇒ Batch systems

⇒ Flow systems

- Segmented flow analysis (SFA)
- Continuous sample flow

CVAAS - Continuous sample flow system

ICFIA 2005

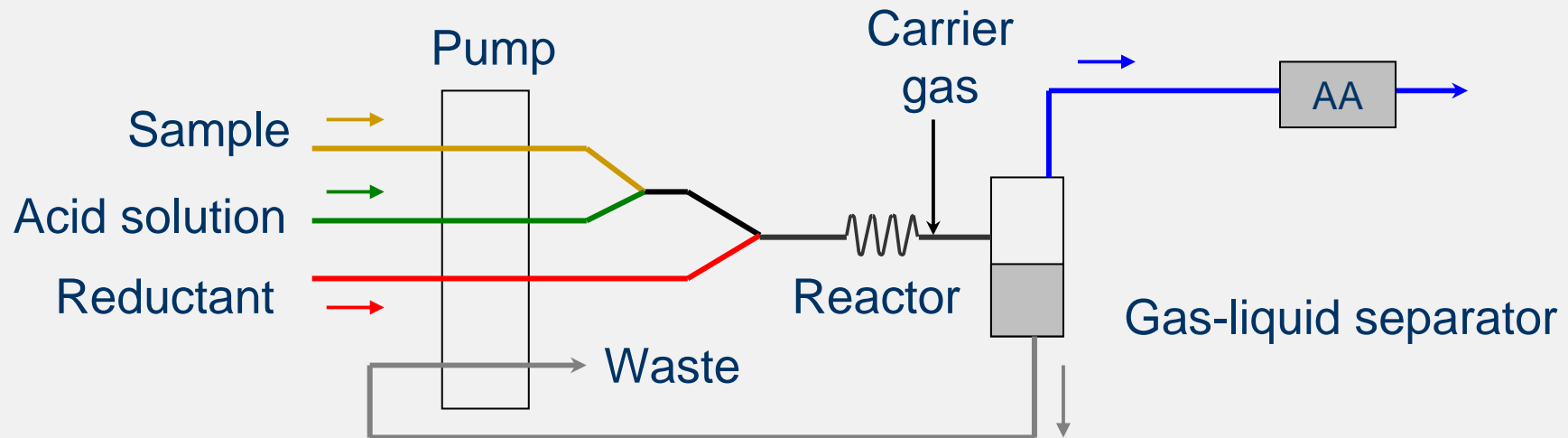

⇒ Batch systems

⇒ Flow systems

- Segmented flow analysis (SFA)
- Continuous sample flow
- Flow injection analysis (FIA)

Andrade et al, 1983, *Spectrochim. Acta*

CVAAS - Flow injection system (FIA)

ICFIA 2005

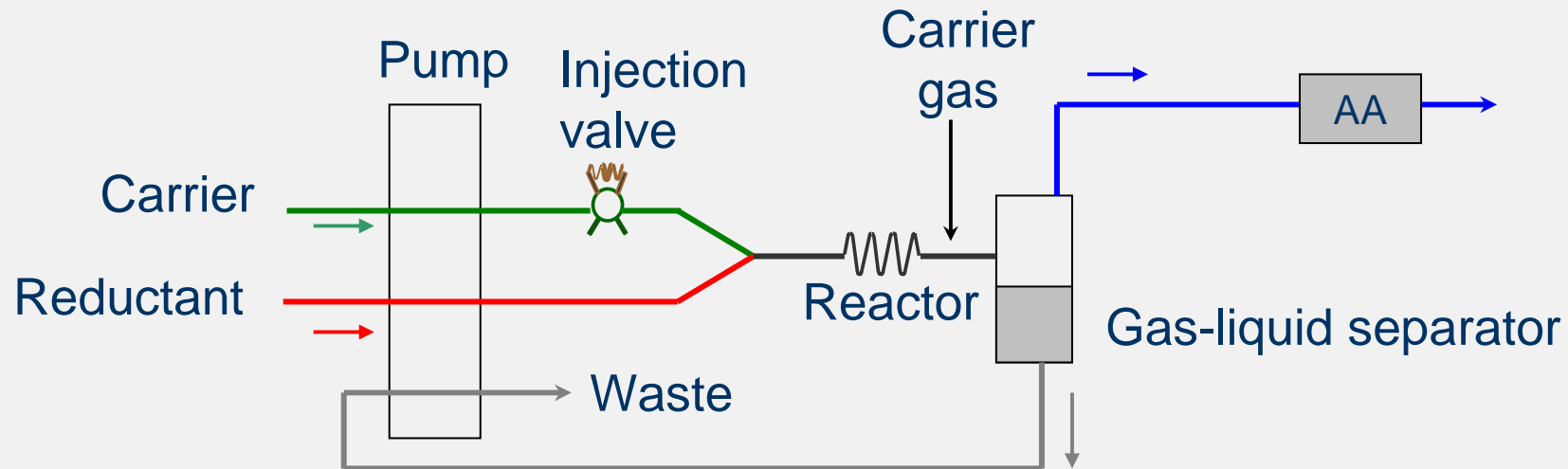

- ⬆ sampling rate
- ⬆ small and variable sample volumes
- ⬆ higher precision

➔ Batch systems

➔ Flow systems

- Segmented flow analysis (SFA)
- Continuous sample flow
- Flow injection analysis (FIA)

Andrade et al, 1983, *Spectrochim. Acta*

- Sequential injection analysis (SIA)

Reis et al, ACA 293(1994)129.

Aspiration

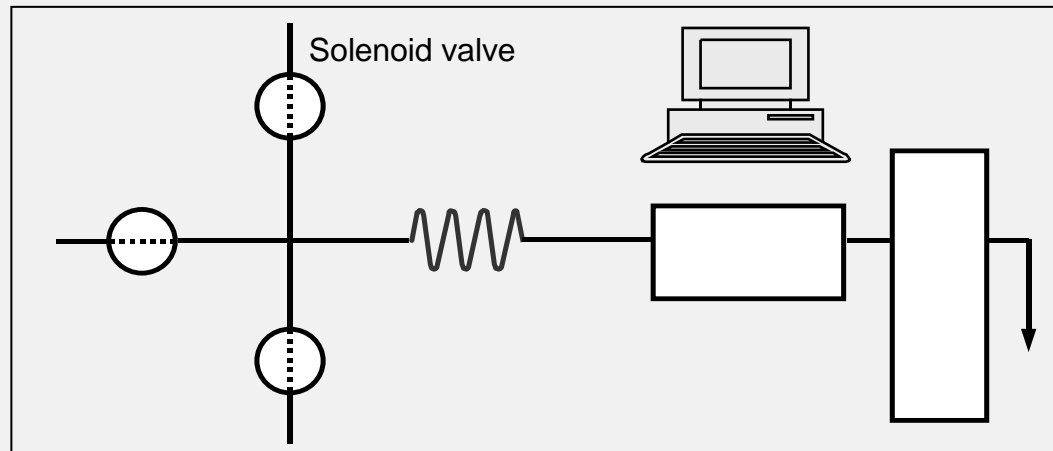

Propulsion

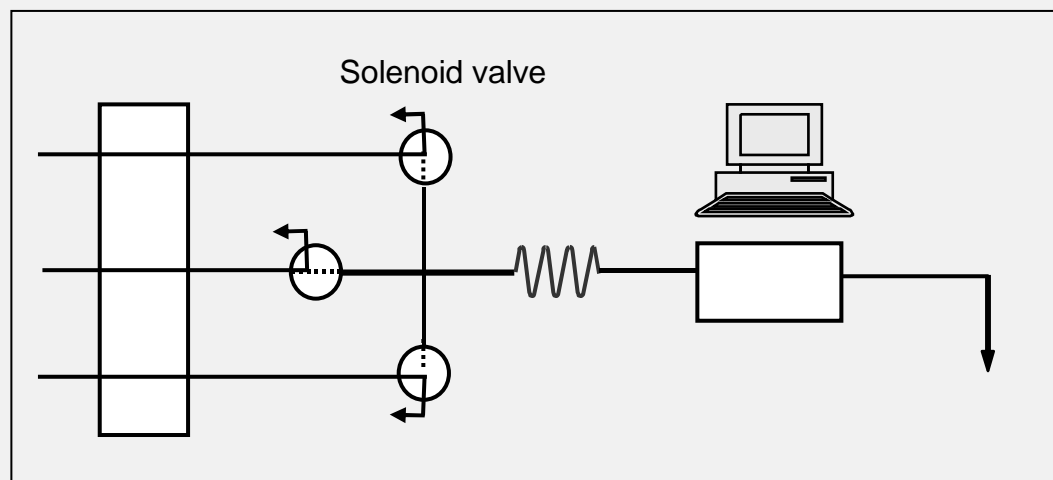

Advantages

- ➔ Miniaturisation of flow systems
- ➔ Improved mixing conditions
- ➔ Reduced sample and reagent consumption
- ➔ Flexibility

Limitations

- ➔ The need to aspirate the solutions (or re-circulating the solutions)
- ➔ Limited commercial availability
- ➔ Lack of robustness of the valves

- ➔ Calibration procedure using a single standard solution
- ➔ Reagent/sample reduction
- ➔ Waste reduction
- ➔ Application to the determination of mercury in fish samples

Flow manifold

ICFIA 2005

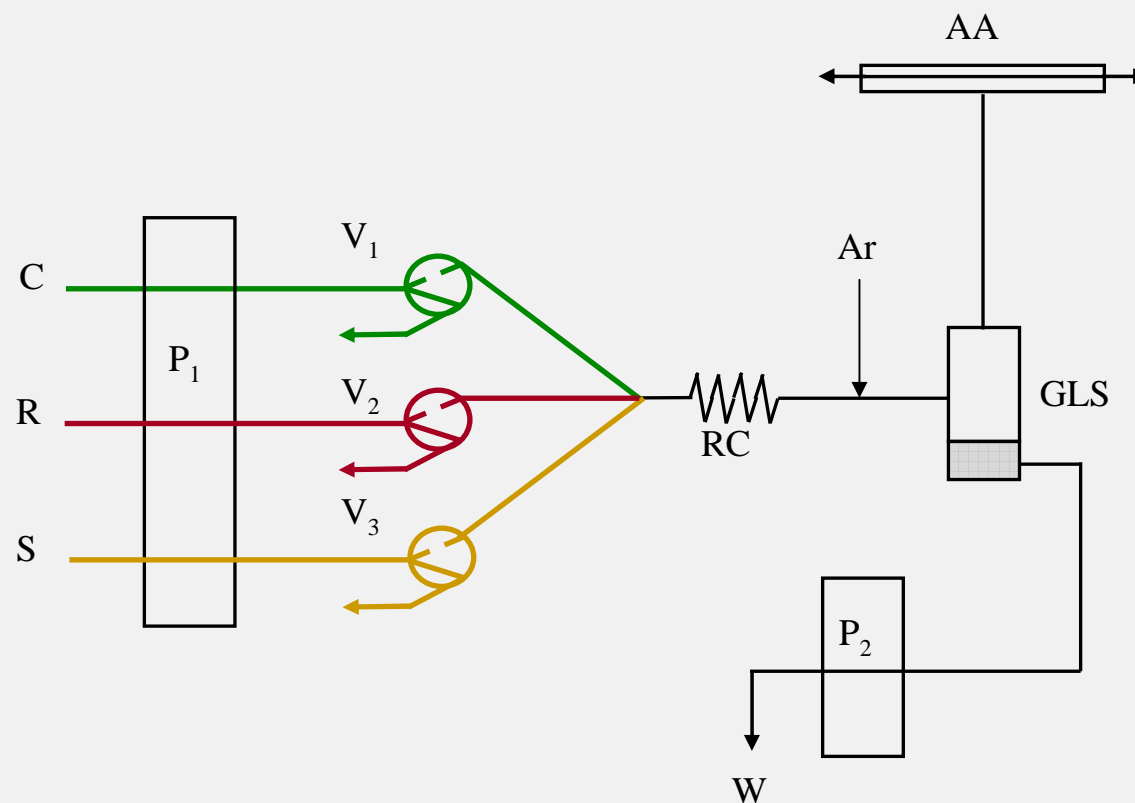
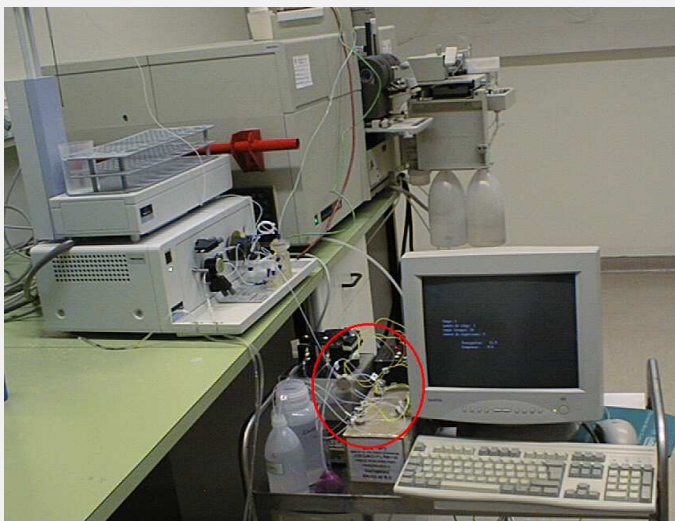

C: carrier HCl 3% v/v (flow rate: 11 ml min⁻¹); **R:** reducing solution NaBH₄ 0.2% m/v in NaOH 0.05% m/v (flow rate: 6 ml min⁻¹); **S:** sample/standard solutions; **RC:** reactor, 30 cm; **Ar:** argon (flow rate: 70 ml min⁻¹); **AA:** atomic absorption spectrophotometer; **V₁-V₃:** solenoid valves; **GLS:** gas-liquid separator; **P₁,P₂:** peristaltic pumps; **W:** waste.

Timing course of the valves

ICFIA 2005

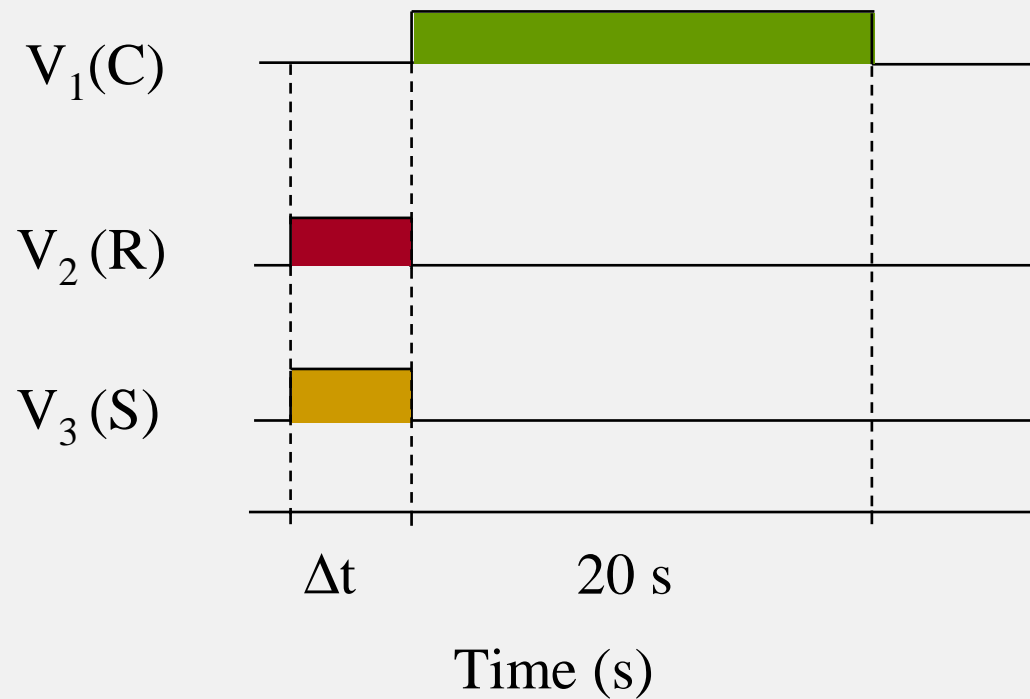

Single standard calibration



Δt : sampling time (0.5-10 s)

Traditional calibration



Δt : sampling time (5 s)

	<i>FIAS 100</i>	<i>MCFIA</i>	<i>MCFIA Single standard calibration (10ppb)</i>
Limit of detection (ng)	0.08	0.13	0.10
Limit of quantification (ng)	0.21	0.34	0.34
RSD %	4.7 (0.83 ng)	5.8 (0.83 ng)	6.2 (0.80 ng)
	1.7 (4.1 ng)	2.7 (4.2 ng)	1.9 (4.9 ng)
Linear range (ng)	0 – 10	0 – 10	0 – 10
Regression equation ^b			
m, slope	0.112 (±0.005)	0.130 (±0.008)	0.112 (±0.006)
b, intercept	0.014 (±0.014)	0.002 (±0.002)	0.018 (±0.012)
Correlation coefficient	0.9998	0.9994	0.9988
Sampling rate	90 h ⁻¹	60 h ⁻¹	60 h ⁻¹

^b Mean ± std deviation of 7 different working days

	FIAS 100	MCFIA	MCFIA Single standard calibration (10 ppb)
Sample consumption ^b	500 µl	500 µl	50 – 1000 µl
HCl consumption ^b	0.25 ml	0.11 ml	0.11 ml
NaBH ₄ consumption ^b	0.9 mg	1.0 mg	0.1 – 2.0 mg
NaOH consumption ^b	0.23 mg	0.25 mg	0.025 – 0.50 mg
Waste ^b	13.3 ml	4.7 ml	3.8 – 5.7 ml

^b Values per assay

	Certified value mg/Kg	MCFIA ^b mg/Kg	MCFIA Single standard calibration ^b mg/Kg
Dogfish (DORM-2)	4.64 ± 0.26	4.37 ± 0.13	4.44 ± 0.28

^b average value ± std deviation of two working days with 3 replicates analysed each day (n=6)

	Without spike ($\mu\text{g/Kg}$)	Spiked (ng)	MCFIA Recovery (%) ^b	MCFIA Single standard calibration Recovery (%) ^b
Cod	57	200	98.6 \pm 0.8	104.6 \pm 0.9
		500	99.8 \pm 0.3	109.6 \pm 0.4
		1000	96.9 \pm 2.5	104.5 \pm 2.6
Shellfish	\leq LOQ (9 $\mu\text{g/Kg}$)	200	90.7 \pm 5.5	96.6 \pm 3.7
		500	94.1 \pm 2.7	105.6 \pm 3.3
		1000	95.4 \pm 1.2	107.1 \pm 1.3

^b Mean \pm std deviation (n=3)

Different volumes of the same sample/standard solution are intercalated in the system



plotting peak area versus injection time



sample calibration curve

The linear relationship $A = m V + b$
theoretically $b=0$

Beer's law

$$A = \varepsilon l C$$



$$C^* = \frac{C_{\text{std}} \times m^*}{m_{\text{std}}}$$

Slope comparasion method

ICFIA 2005

	Correlation coefficient	Slope ^b	Recovery %
Sample without addition	0.9975	0.018±0.001	-
Sample solution			
Addition 2 ppb	0.9976	0.039±0.001	92.4±7.6
Addition 5 ppb	0.9995	0.076±0.001	103.6±3.7
Addition 10 ppb	0.9994	0.138±0.001	107.2±2.3
Standard 10 ppb	0.9995	0.111±0.002	-

^b mean ± Std deviation (n=3)

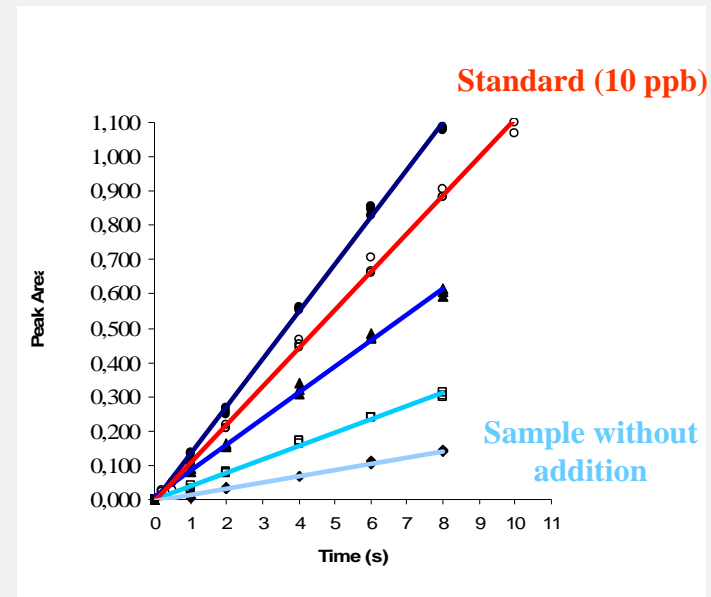

Slope comparasion method

ICFIA 2005

	Correlation ^b coefficient	Slope ^b	Concentration ^b Hg mg/Kg
Dorm-2 (Dogfish)	0.9982	0.266±0.011	4.54±0.02
Dorm-2 Diluted solution	0.9996	0.140±0.003	4.77±0.09
Standard 10 ppb	0.9987	0.115±0.001	-

^b Mean ± Std deviation (n=3)

Dogfish (Dorm-2): Certified value = 4.64± 0.26 mg/Kg

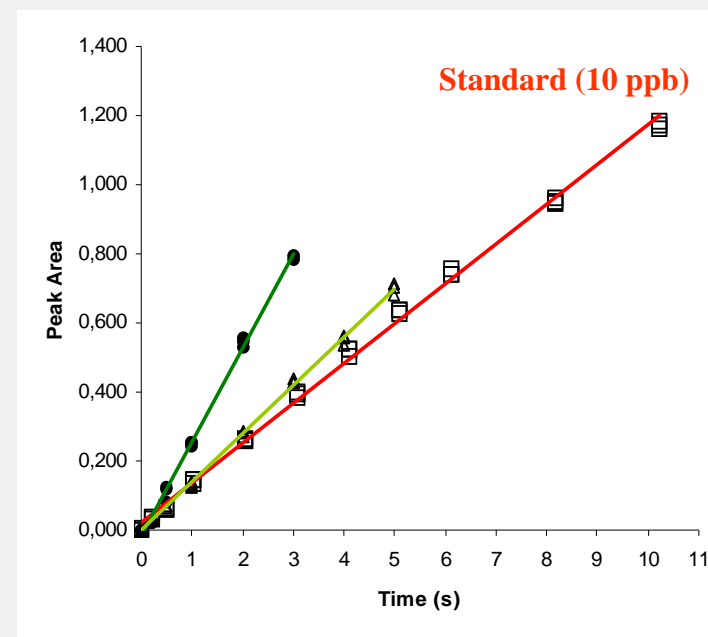

Making use of the linear relation between the signal (peak area) and injection time the concentration of the sample can also be accurately determined.

- ✓ The developed multicommutated flow system is accurate and precise for the determination of mercury in fish samples
- ✓ Advantage over the traditional calibration
 - ↳ Less time consuming
 - ↳ Reagent/standard consumption
 - ↳ Waste production
- ✓ Sample dilution is easily adjusted
- ✓ This methodology can be extended to other elements forming volatile hydrides

Porto, Portugal



I. V. T. thanks Fundação para a Ciência e a Tecnologia (FCT) and the III Quadro Comunitário de Apoio through Fundo Social Europeu and MCES for the grant SFRH/BPD/5631/2001