

Influence of air-drying temperature on the quality and bioactive characteristics of dried Galega kale (*Brassica Oleracea* L. Var. *Acephala*)

Sara M. Oliveira, Inês N. Ramos, Teresa R. S. Brandão and Cristina L. M. Silva*

*clsilva@porto.ucp.pt



CBQF – Centro de Biotecnologia e Química Fina – Laboratório Associado, Escola Superior de Biotecnologia, Universidade Católica Portuguesa/Porto, Rua Arquiteto Lobão Vital, Apartado 2511, 4202-401 Porto, Portugal



Introduction

✓ Galega kale (*Brassica Oleracea* L. var. *Acephala*)

- Traditional fresh-cut vegetable
- High amounts of vitamins and other micronutrients
- Often included as soups ingredient
- High moisture content → compromised preservation

✓ Convective drying

- Preserve and increase the shelf-life of perishable food products
- Facilitates storage and transport, and reduces packaging costs
- Frequently used by food industrials to attain large amount of dried vegetables
- Physical, biological and chemical modifications → may affect the overall quality of the dried products and the consumer's acceptance

✓ Objective

- Study the influence of air-drying temperature on the drying characteristics and some quality parameters of Galega kale

Materials & Methods

✓ Drying equipment

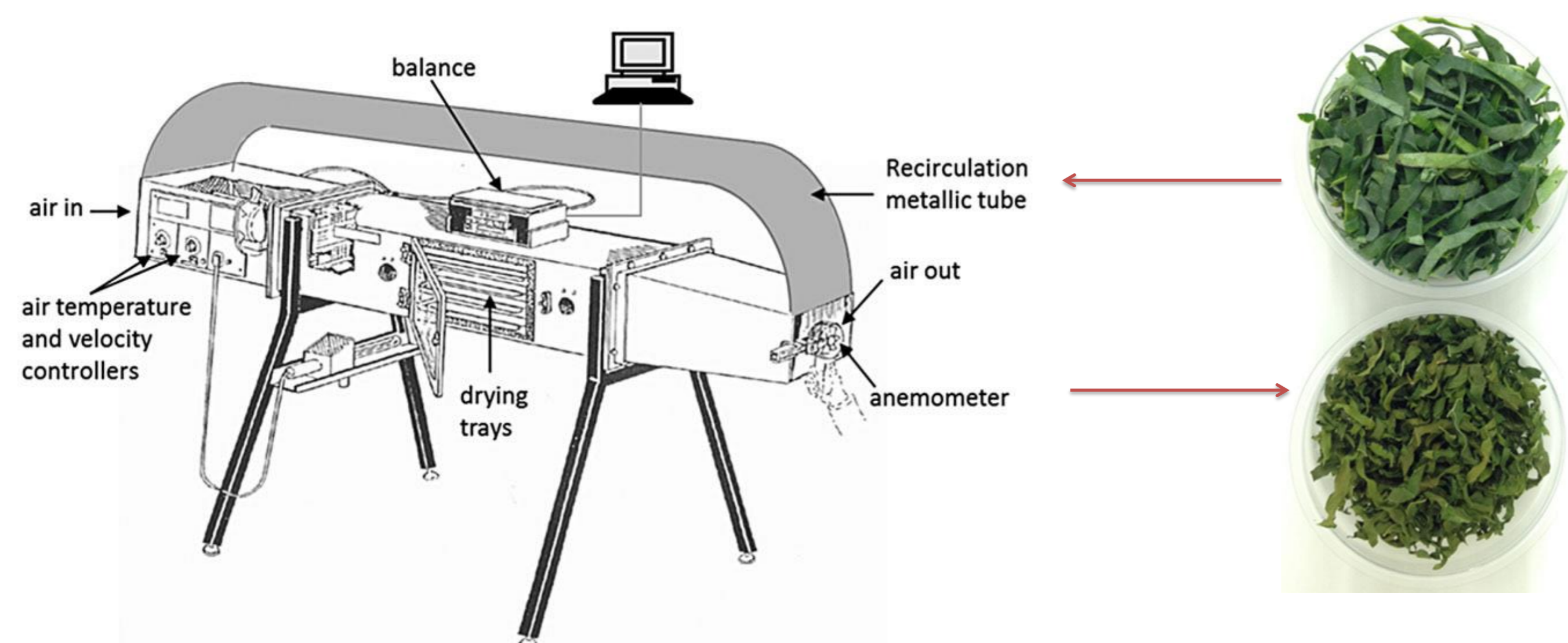

✓ Quality parameters

- Water activity: Water activity meter
- Color properties: colorimeter
- Chlorophylls: absorbance reading at 665.2 and 652.4 nm
- Vitamin C: HPLC analysis, reverse phase C18-silica analytical column
- Total phenolic compounds: Folin–Ciocalteu method
- Total antioxidant capacity (TAOC): direct production of ABTS chromophore



Results & Discussion

✓ Drying curves

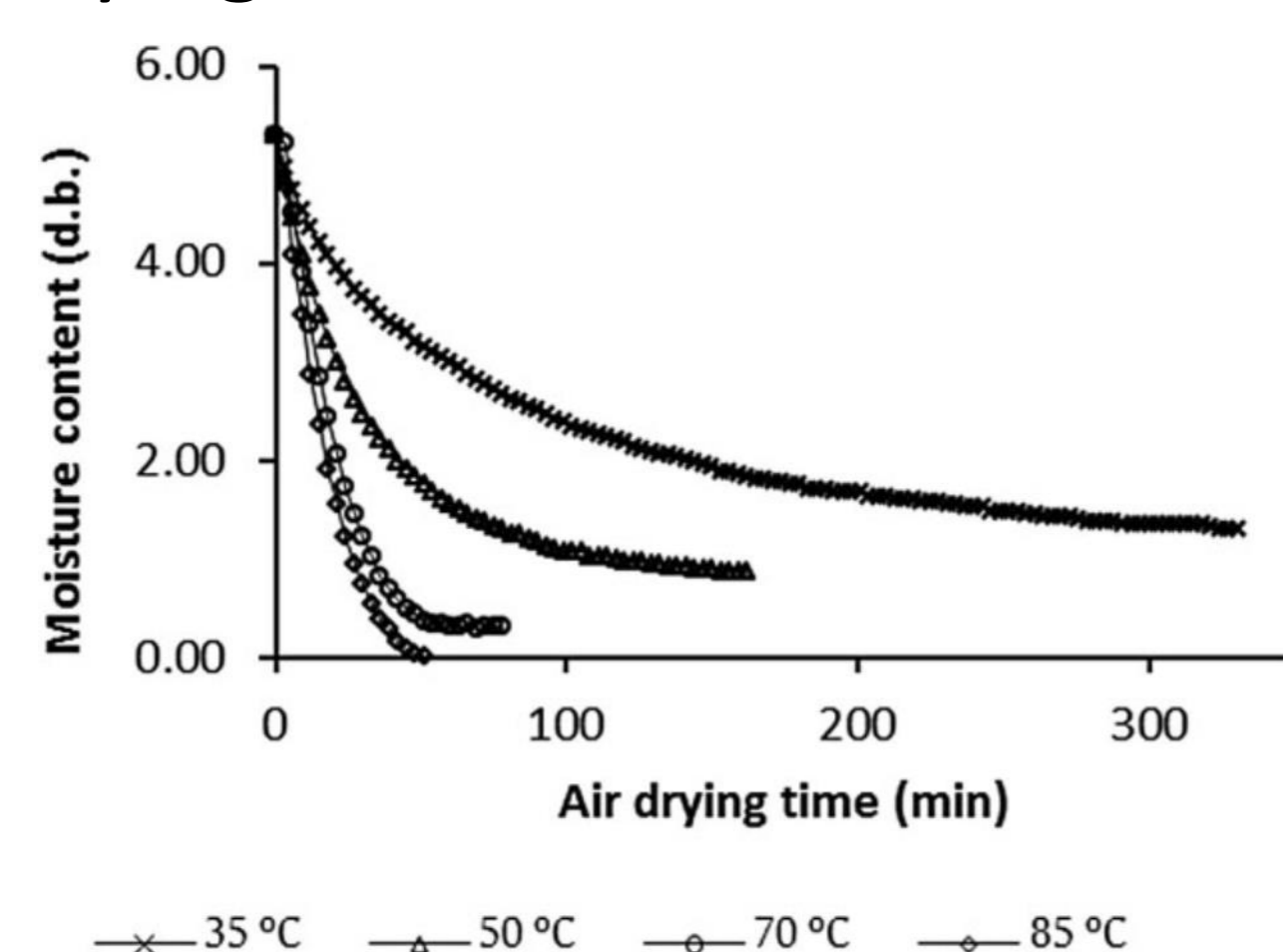

✓ Drying rate curves

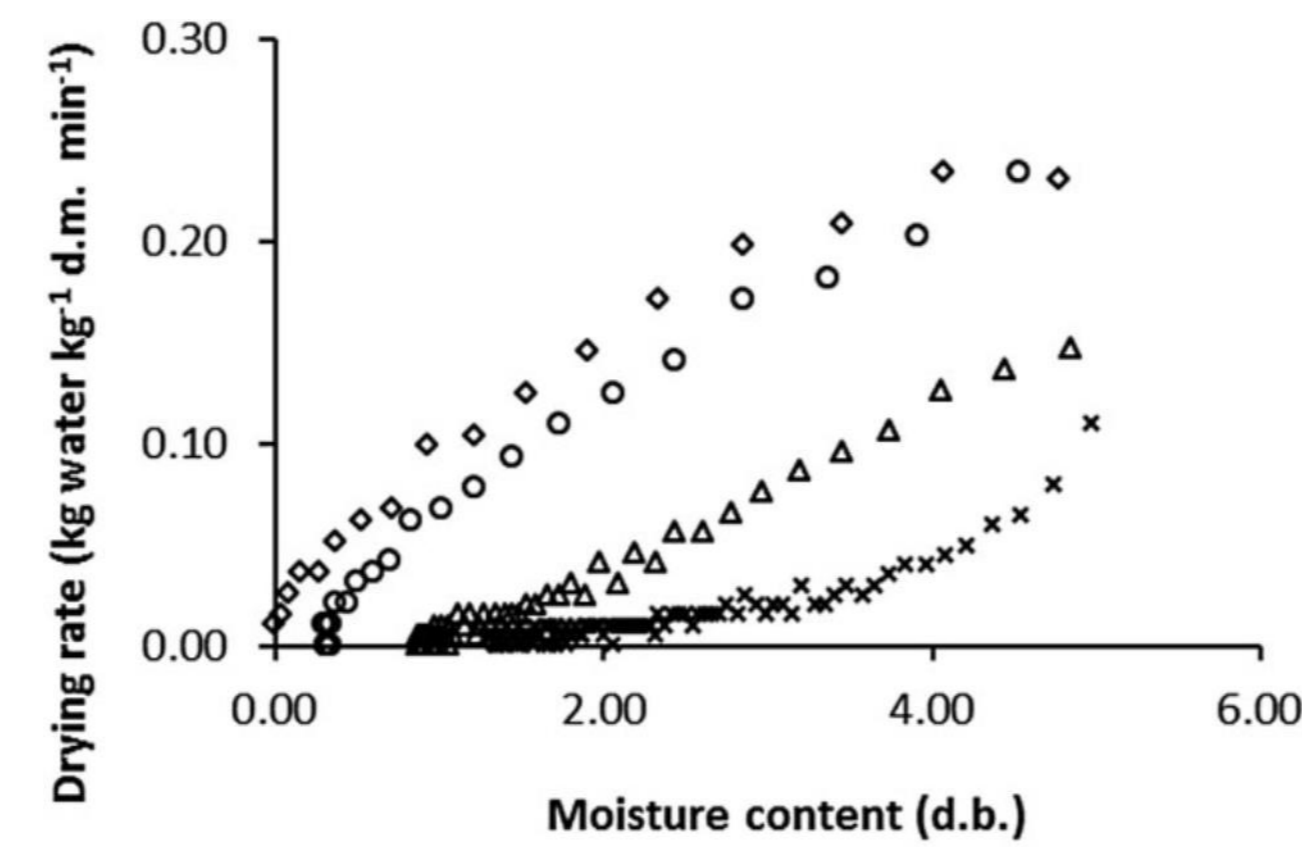

✓ Water activity, final moisture content and air relative humidity

Drying temperature (C)	Water activity ^a	Final moisture content (d.b.)	Air relative humidity (%) ^b
35	0.525 ± 0.001	1.29	43.0 ± 3.3
50	0.487 ± 0.001	0.88	24.8 ± 0.6
70	0.465 ± 0.008	0.29	13.9 ± 0.4
85	0.461 ± 0.001	0.01	10.7 ± 0.5

^a Values expressed as mean ± standard deviation, n = 3. Values expressed as mean ± standard deviation, n = 5.

Results & Discussion (Cont.)

✓ Color parameters

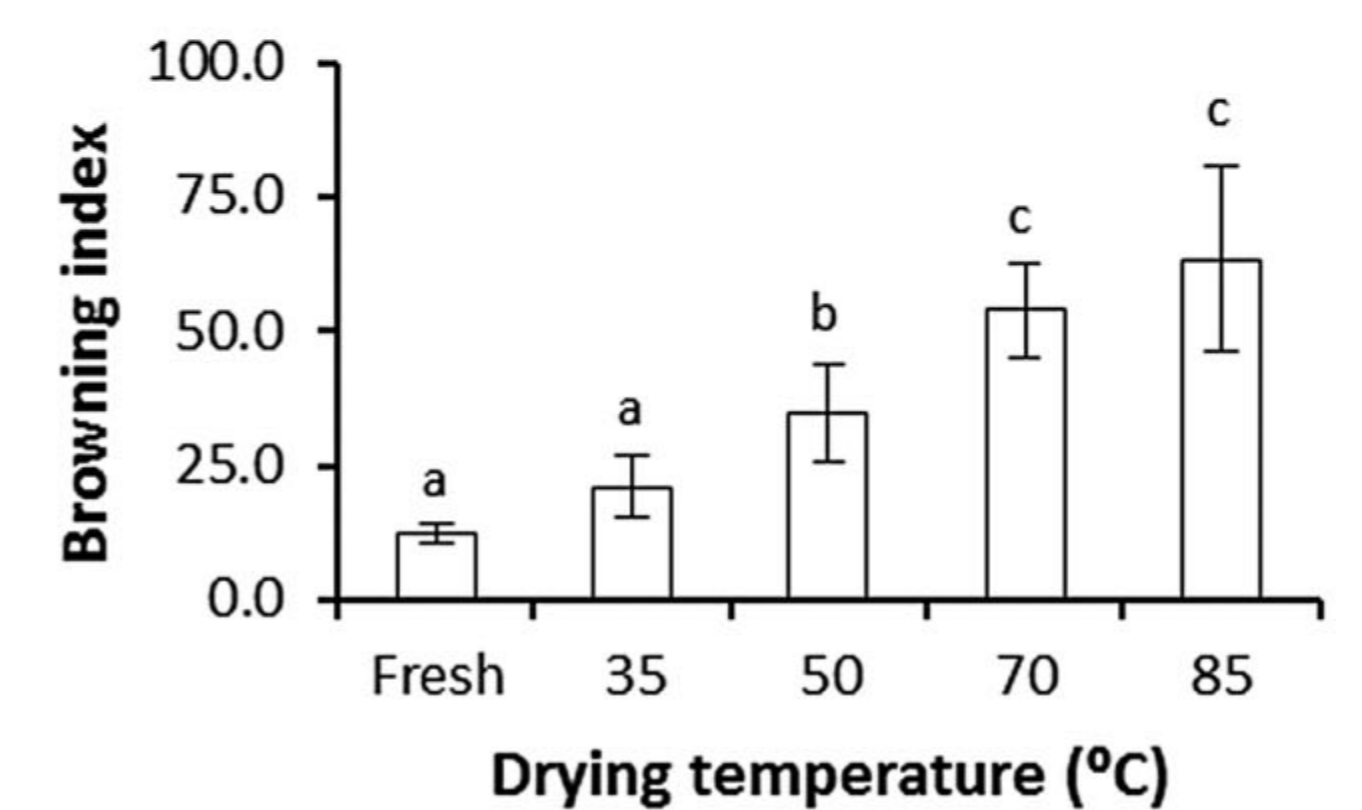
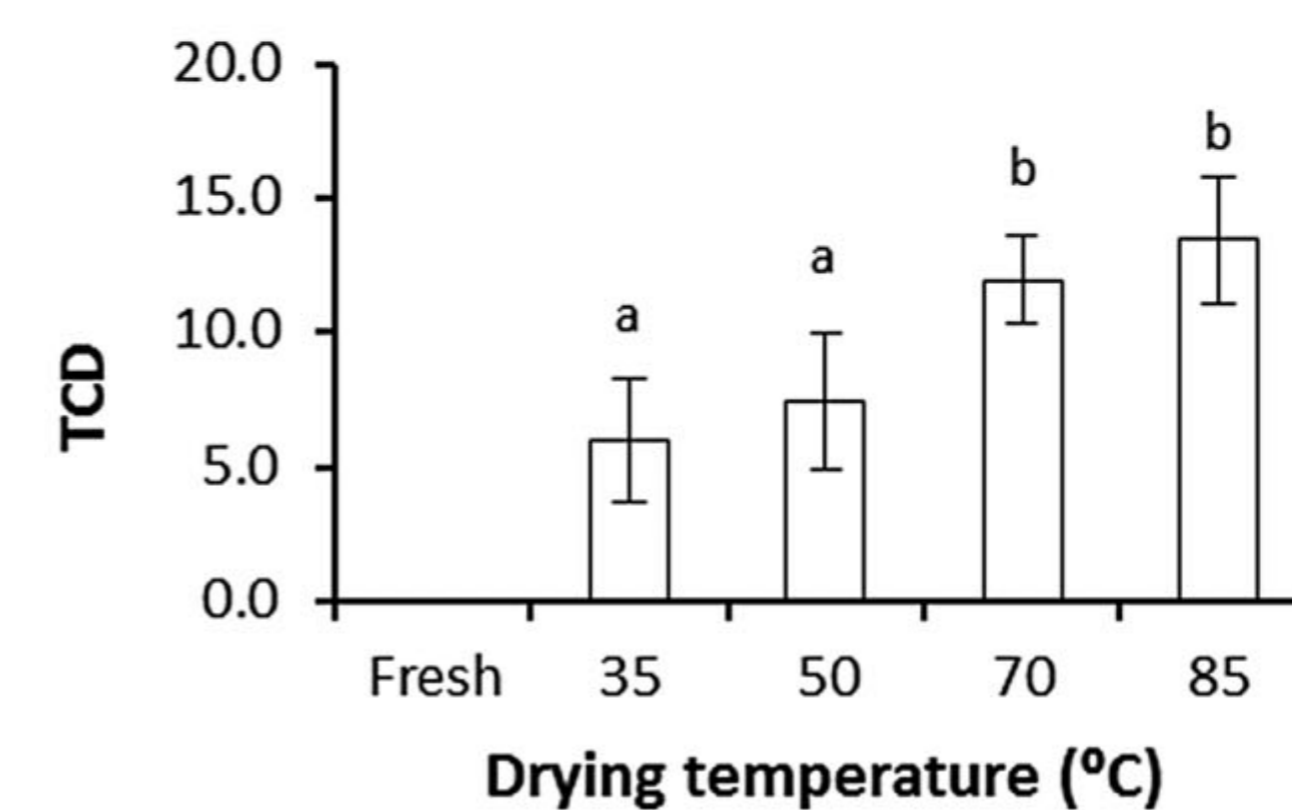
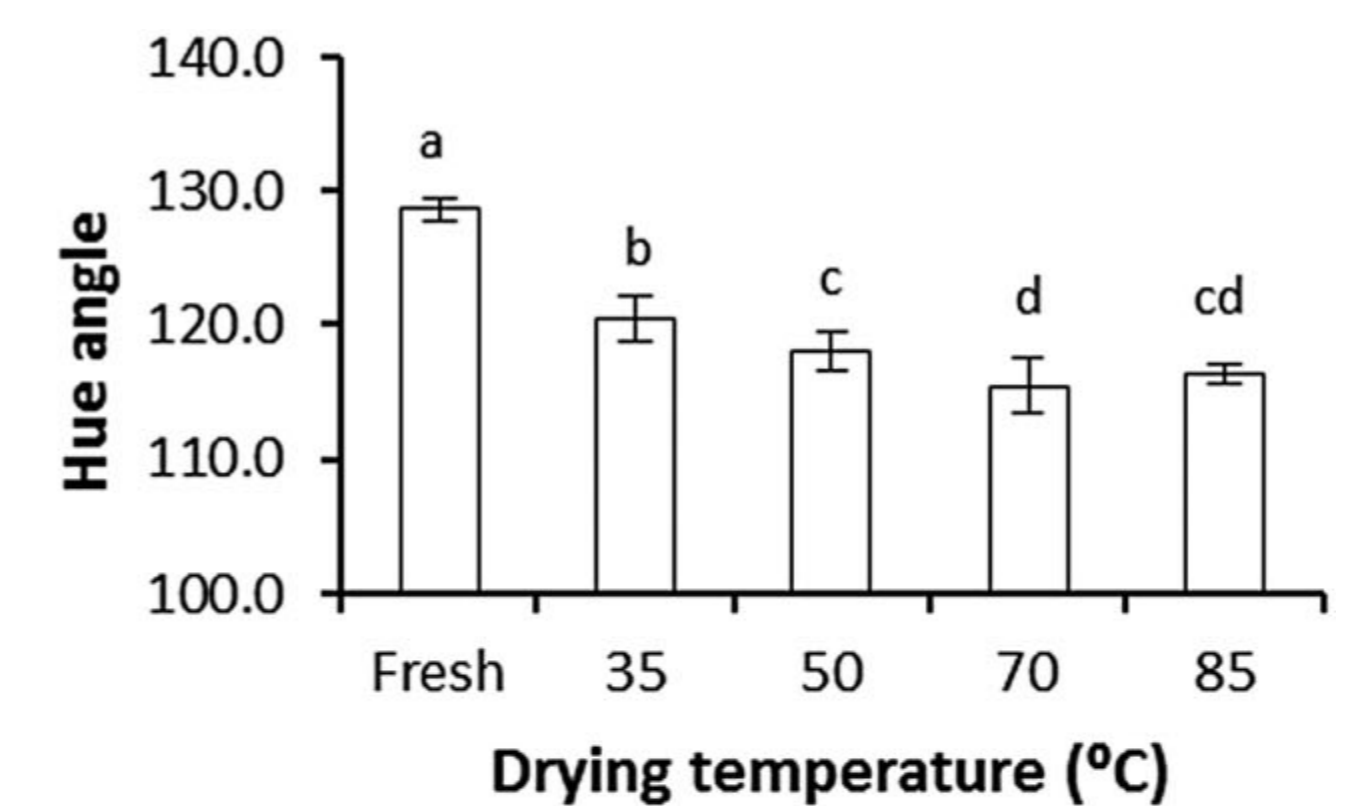
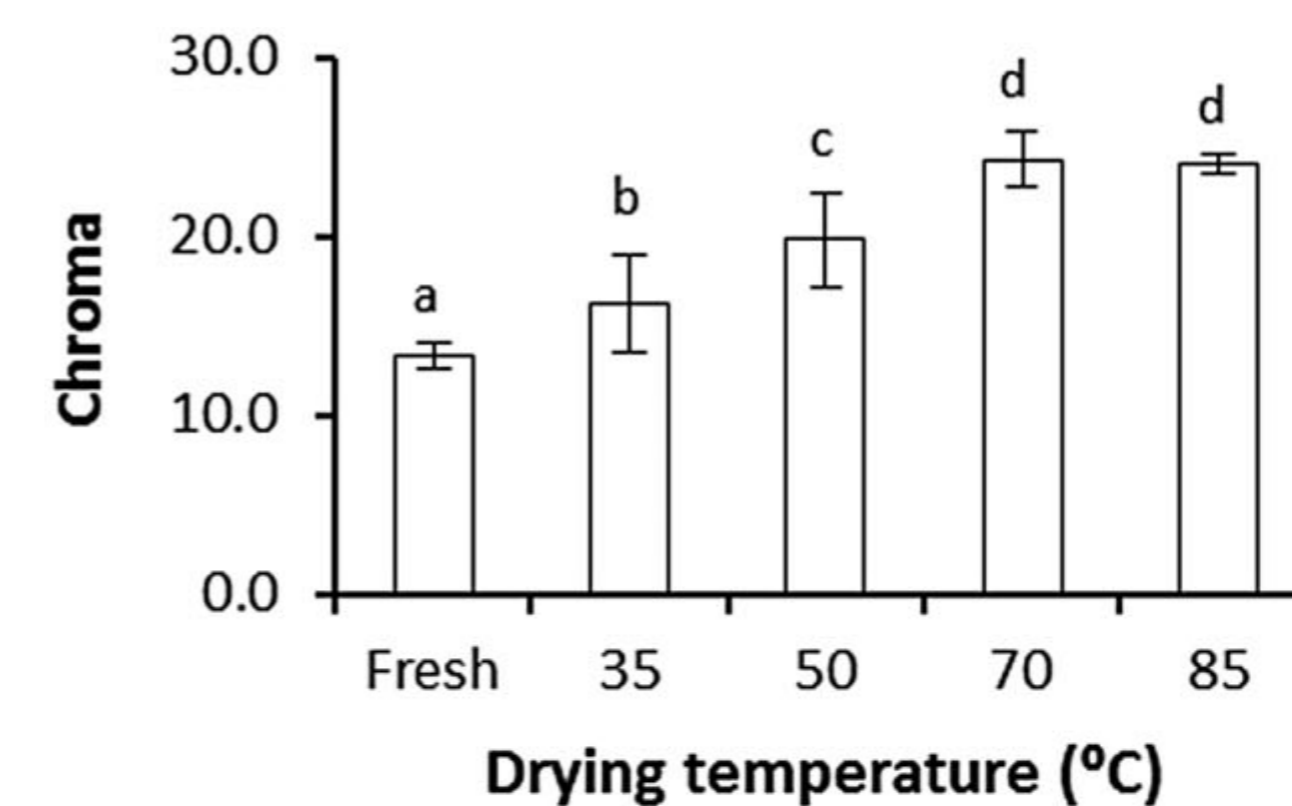

✓ Vitamin C

Drying temperature (C)	Vitamin C (mg/100 g d.m.)	Retention (%)
Fresh	566.1 ± 23.3 ^a	–
35	539.0 ± 54.8 ^a	95.2 ± 9.7
50	379.2 ± 44.0 ^b	67.0 ± 7.8
70	336.3 ± 47.0 ^{bc}	59.4 ± 8.3
85	252.1 ± 42.0 ^c	44.5 ± 7.4

Notes: Values are expressed as mean ± standard deviation, n = 4. Values with the same letter in the first column were not significantly different (P > 0.05).

✓ Total phenolic content

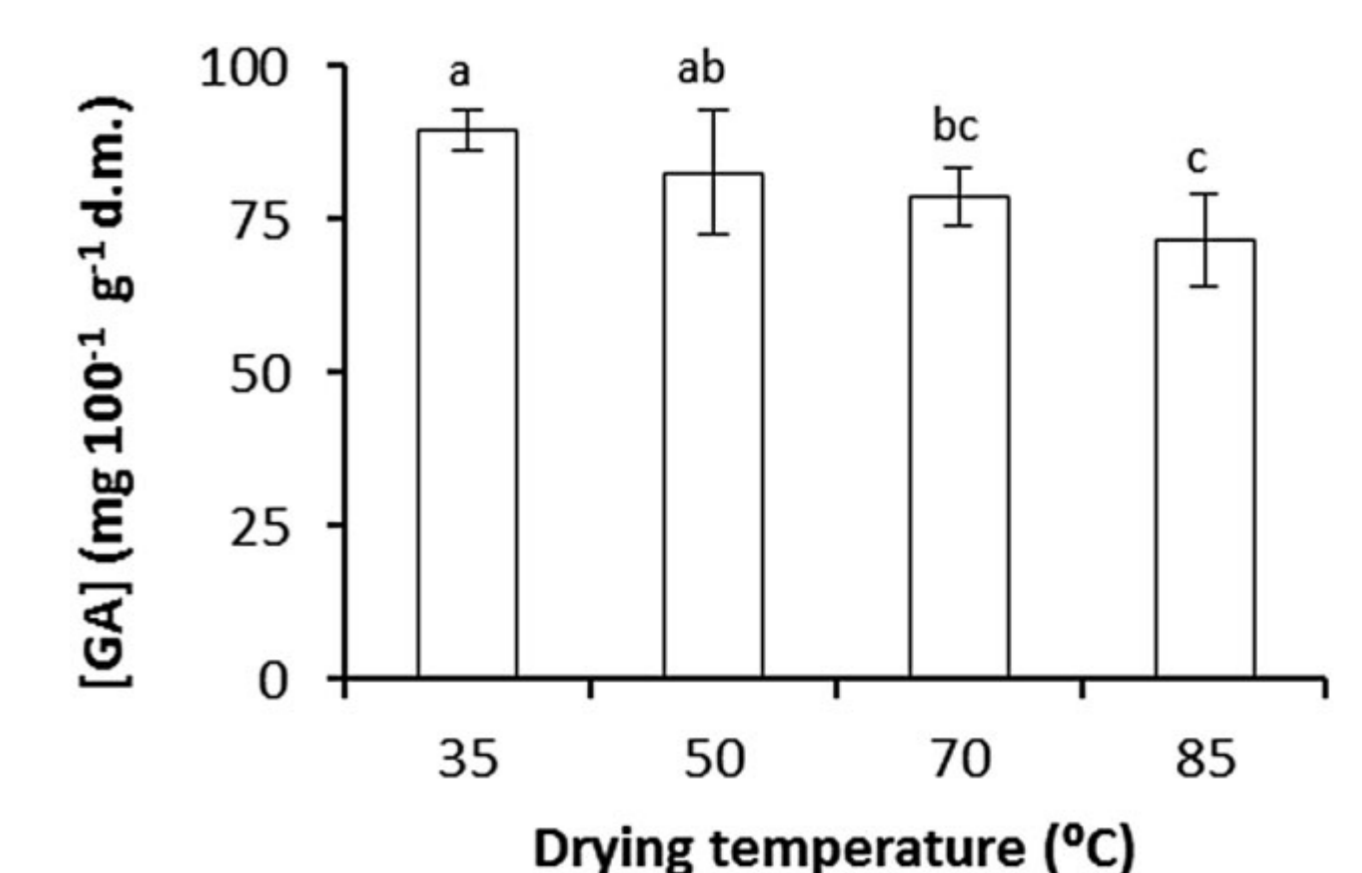

✓ Total antioxidant capacity

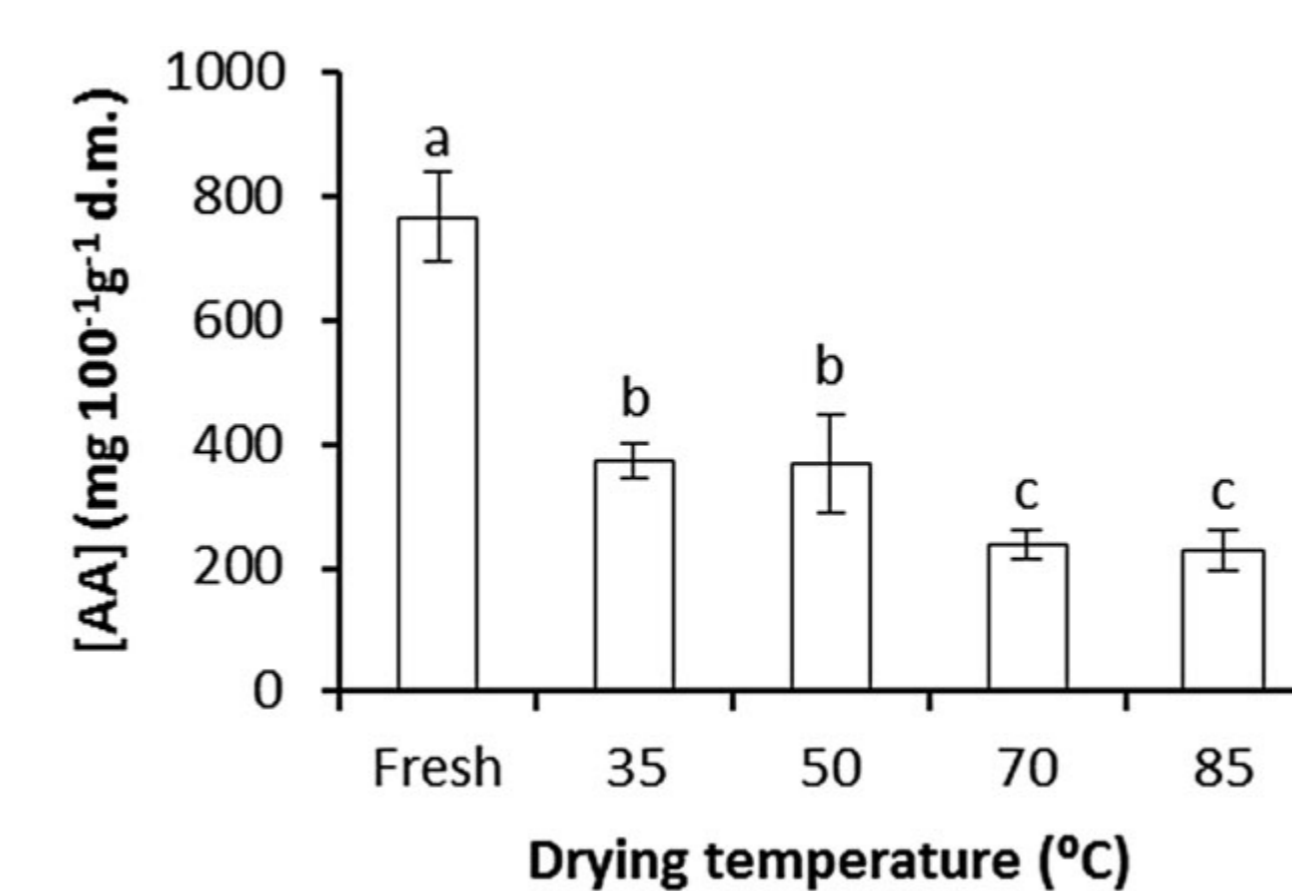

✓ Chlorophylls

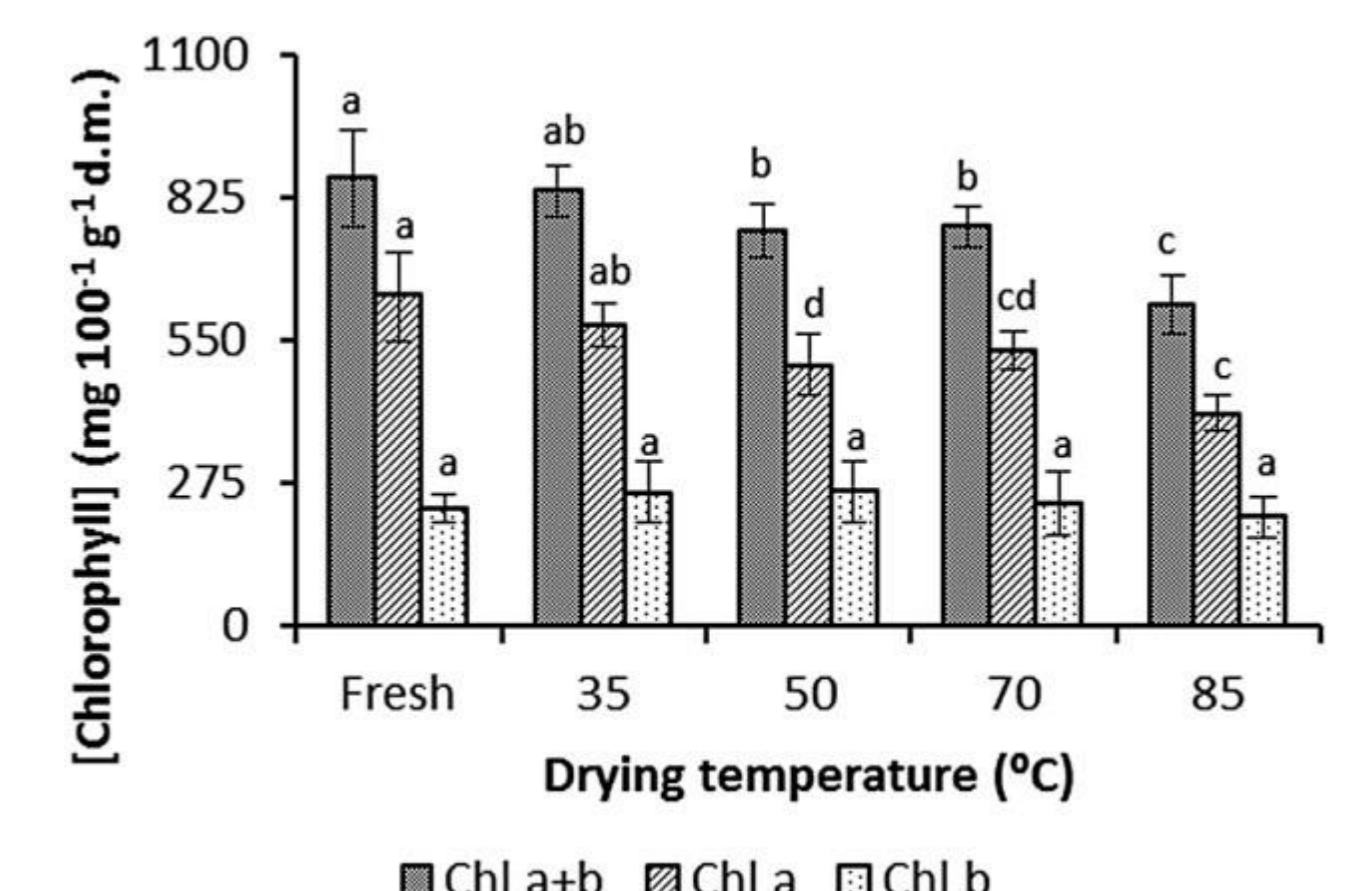

Conclusions

✓ Increasing drying temperatures

- Reduction of the drying time, increase of the drying rate
- Decrease of water activity, final moisture content, and air relative humidity

✓ Convective drying of Galega kale without any pretreatment

- Significant quality deterioration, especially at high temperatures
 - Important nutritive losses: vitamin C, total phenolics and TAOC decreased with increasing temperatures
 - Color parameters also indicated product worsening
 - Degradation of chlorophyll *a* more pronounced at higher temperatures
 - Chlorophyll *b*: high thermal-stability → stable for all temperatures

✓ Further studies

- Evaluate pretreatments to prevent nutrients degradation and minimize color modifications → improve overall quality

Acknowledgements

- ✓ Sara M. Oliveira, Inês N. Ramos and Teresa R. S. Brandão gratefully acknowledge to Fundação para a Ciência e a Tecnologia (FCT) and Fundo Social Europeu (FSE) the financial support through the Post-Doctoral grants SFRH/BPD/74815/2010, SFRH/BPD/75430/2010 and SFRH/BPD/101179/2014, respectively.
- ✓ Work supported by National Funds from FCT through project PEst-OE/EQB/LA0016/2013.